

Experimental verification of extraordinary transmission without surface plasmons

F. Medina,^{1,a)} J. A. Ruiz-Cruz,^{2,b)} F. Mesa,^{3,c)} J. M. Rebollar,^{4,d)} J. R. Montejo-Garai,^{4,e)} and R. Marqués^{1,f)}

¹Department of Electronics and Electromagnetism, University of Seville, 41012 Seville, Spain

²Escuela Politécnica Superior, Universidad Autónoma de Madrid, E-28049 Madrid, Spain

³Department of Applied Physics I, University of Seville, 41012 Seville, Spain

⁴Dept. Electromagnetismo & Teoría de Circuitos, Universidad Politécnica de Madrid, 28040 Madrid, Spain

(Received 16 June 2009; accepted 28 July 2009; published online 17 August 2009)

This letter provides an experimental demonstration of extraordinary transmission in a closed waveguide system loaded with an electrically small diaphragm. This is a situation where the standard surface plasmon polariton (SPP) theory does not apply. The theoretical explanation is then based on the concept of impedance matching. This concept has previously been applied by some of the authors to account for enhanced transmission in situations where surface plasmon theory can be used: periodic arrays of small holes or slits in flat metal screens. The experiment in this letter supports the impedance matching model, valid for when SPPs are present or not. © 2009 American Institute of Physics. [DOI: 10.1063/1.3206738]

After the discovery of the phenomenon of extraordinary transmission (ET) of light through periodically perforated metal screens,¹ there has been a lot of research activity on this topic. In the first stage, the ET phenomenon at optical frequencies was associated with the excitation of surface plasmon polaritons (SPPs).² However, the existence of this phenomenon also at microwave and millimeter wave frequencies³ (where metals basically behave as quasiperfect conductors) makes it evident that the excitation of standard SPP cannot be essential for the enhanced transmission of electromagnetic waves. A detailed review of ET for both perfect conductors and real metals can be found in Ref. 4, where ET/reflection is linked to the periodic distribution of holes/scatterers. The necessity of a surface wave, acting as an intermediary agent in the ET/reflection phenomenon, was rescued in the frame of perfect conductor systems after noting that periodically structured perfect-conductor surfaces can support quasibound surface waves that *mimic* the role of true SPPs. These waves have been called *spoof plasmons* in a relevant paper on the topic,⁵ but they are also called SPP-Bloch waves.⁶ Experimental evidence of the existence of this kind of waves in the terahertz regime (where metals are conductors working in the skin effect regime) has recently been reported in Ref. 7. It is worth mentioning that in the microwave range, the guiding of surface waves by periodically structured metal surfaces is known since the forties^{8–10} and its study is included in advanced textbooks.¹¹ Nevertheless, these works typically restricted themselves to one-dimensional (1D) periodic structures, and certainly the connection of ET with this kind of waves was not reported before. Surface-wave guiding associated with periodicity is also known in the optical regime¹² and thus the same theoretical framework used at microwaves could be used to ex-

plain ET at optical frequencies, although some differences due to the different behavior of metals at low and high frequencies still can be found.^{2,4}

Parallel to the well-founded SPP theory commented above,^{13,14} some of the authors of this letter have recently proposed an alternative interpretation of the ET mechanism¹⁵ through periodically perforated metallic screens that is based on the theory of scattering by obstacles inside closed (hollow pipes) waveguides.¹¹ More specifically, our approach poses the problem in terms of the scattering of a transverse electromagnetic (TEM) mode by a diaphragm of arbitrary thickness and arbitrary aperture size located inside a parallel plate waveguide with lateral magnetic walls. This simple equivalent model accounts even for the finest details of the transmission spectra reported by many authors for the case of two-dimensional (2D) periodically perforated perfect conducting screens of arbitrary thickness. In the frame of this alternative theory, the basic concept that explains ET is *impedance matching* rather than surface wave excitation. Nevertheless, the ET frequencies predicted by the impedance matching model and by the SPP-Bloch wave model are expected to be very close when relatively small holes are considered (in this case, the ET frequencies are also very close to the first Rayleigh–Wood anomaly frequency).¹⁶ In general, the differences between SPP-Bloch wave predictions and impedance matching predictions are more qualitative than quantitative. The SPP-Bloch wave model implicitly requires the existence of a *periodic* system supporting surface waves. For the impedance matching model, this requirement will be just a particular case for which ET transmission is possible. Actually, the impedance matching model predicts enhanced transmission in systems that are not periodic at all and where SPPs are not even defined. One of these systems could be, for instance, a common rectangular metallic waveguide with a diaphragm having a relatively small hole in it. This possibility has been briefly discussed in Ref. 15, using the example of a circular waveguide with a centered diaphragm. The authors of this letter have found at least four other relevant papers reporting on this possibility.^{17–20} However, the

^{a)}Electronic mail: medina@us.es.

^{b)}Electronic mail: jorge.ruizcruz@uam.es.

^{c)}Electronic mail: mesa@us.es.

^{d)}Electronic mail: jmrm@etc.upm.es.

^{e)}Electronic mail: jr@etc.upm.es.

^{f)}Electronic mail: marques@us.es.

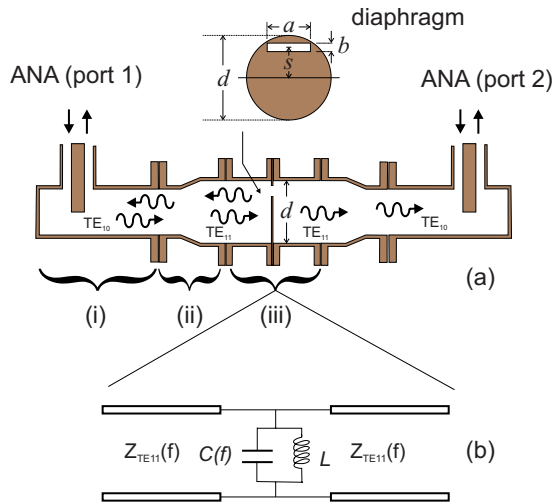

FIG. 1. (Color online) (a) Experimental measurement setup. The two ports of an automatic network analyzer are connected to the diaphragm inside the circular waveguide to be measured. Section (i) is a standard coax-to-rectangular waveguide transition. Section (ii) is a rectangular waveguide TE_{10} to circular waveguide TE_{11} low reflection mode converter. Section (iii) is a circular waveguide section with a diaphragm inside (frontal view is shown in the picture above). Dimensions: $d=19.45$ mm, $a=10$ mm, $s=7$ mm, and $b=2$ mm. The thickness of the diaphragm is 0.35 mm. TM_{01} mode cutoff occurs at 11.80 GHz. The natural resonance frequency of the rectangular slot is close to 15 GHz. (b) Equivalent circuit for the middle section of the setup in (a). $Z_{TE_{11}}$ is the frequency (f) dependent impedance of the scattered mode.

rectangular waveguide cases treated in those papers are likely not the most convenient examples if one is interested in comparing the predictions of the impedance matching model versus the SPP-Bloch waves model. The reason is that the boundary conditions imposed by the rectangular waveguide problem can be replicated by using two planar uniform waves impinging on the periodically perforated infinite opaque surface with the adequate angle and polarization. Thus, it might be claimed that the rectangular waveguide situation implicitly keeps the periodic nature of a 2D infinite structure. However, if the geometry of the waveguide is circular, there would not be any resemblance with an infinite Cartesian periodic system. Indeed, our formalism predicts ET for arbitrary diaphragms located inside closed hollow pipe waveguides of arbitrary cross section. The circular cross section has the advantage of allowing simple implementation of experiments using standard available microwave components. In this letter, we will report on an experimental setup accounting for the main features of ET in a system without surface plasmons but sharing some properties with the originally studied 2D periodic system.

For this purpose, it will be considered the case of the incidence of the TE_{11} mode (TE stands for transverse electric) of a hollow pipe circular waveguide on an off-centered slit practiced in a metal screen located perpendicularly to the axis of the waveguide [see the central part of the setup shown in Fig. 1(a)]. The TE_{11} mode, which is the fundamental mode of the circular waveguide, would play in the experiment the same role as the TEM mode of the parallel plate waveguide used in Ref. 15, to account for the free-space impinging wave (2D Cartesian periodic system). The first higher order mode that can provide the physical conditions for impedance matching—following the theory in Ref. 15—is the TM_{01} mode (TM stands for transverse magnetic).

In the Cartesian geometry treated in Ref. 15, the mode playing the same role was the TM_{02} mode of the abovementioned rectangular cross-section parallel plate waveguide. In both cases, we have a single propagating mode operating below the cutoff frequency of the first higher-order mode, which is of TM nature. This situation can be represented using the equivalent circuit in Fig. 1(b), where the input and output transmission lines are characterized by the frequency dependent characteristic impedance of the TE_{11} mode, the lumped inductance L accounts for the excess of magnetic energy stored in the below cutoff scattered TE modes, and the lumped capacitance C stands for the electrical energy associated with the scattered higher order TM modes. If the operation frequency is not close to the cutoff frequency of a higher order mode, the values of L and C are almost frequency independent. If L and C are sufficiently large (as would happen if the hole is large enough), the LC-tank circuit would resonate at a frequency well below the onset frequency of the first higher-order TM mode. (In our case, this mode is the TM_{01} , thus this frequency will be denoted as $f_c^{TM_{01}}$). Some authors call this type of resonances *localized waveguide resonances*²¹ to distinguish this operation regime from ET. In such case, the total transmission frequency is very close to the onset frequency of the first mode (of TE type) of the waveguide with the same cross section as the hole. This situation has nothing “special,” as corroborated by the fact that it is well known by designers of frequency selective surfaces since decades ago.²² However, when the hole is electrically small, it could be expected that there were no resonances below $f_c^{TM_{01}}$. Nevertheless, conventional waveguide theory¹¹ says that the contribution of the mode TM_{01} to C is *singular* at its cutoff frequency. More precisely, C has the following closed-form frequency dependence:

$$C(f) = C_0 + \frac{A_{TM_{01}}}{2\pi f \eta_0 \sqrt{\left(\frac{f_c^{TM_{01}}}{f}\right)^2 - 1}}, \quad (1)$$

(f is the natural operation frequency and η_0 is the free space impedance), where the second term is the contribution of the first higher order mode, which has been explicitly separated from all the remaining mode contributions. From Eq. (1) it can easily be deduced that the LC-tank circuit in Fig. 1(b) will always resonate at certain frequency below (and close to) $f_c^{TM_{01}}$, even if the hole is very small. For this resonance the equivalent circuit predicts total transmission (because losses have not been included). It is worth mentioning that our theory also predicts a transmission zero at $f=f_c^{TM_{01}}$ due to the short circuit condition in the capacitor branch (this phenomenon is totally analogous to the Rayleigh–Wood anomaly in periodic gratings).

In order to verify the simple theory briefly explained above, we have used the experimental setup in Fig. 1(a). An Agilent PNA8363B network analyzer has been employed to measure the scattering parameters of an off-centered diaphragm in a circular waveguide. The shape of the hole is rectangular with a large aspect ratio (10:2). In this case, the intrinsic resonance frequency is easily estimated from the condition of half wavelength for the length of the slot. In our experimental setup, with a slot length of 10 mm, it means a resonance frequency around 15 GHz. The off-centered location is chosen to ensure the excitation of the TM_{01} mode, which is required to produce extraordinary (total) transmis-

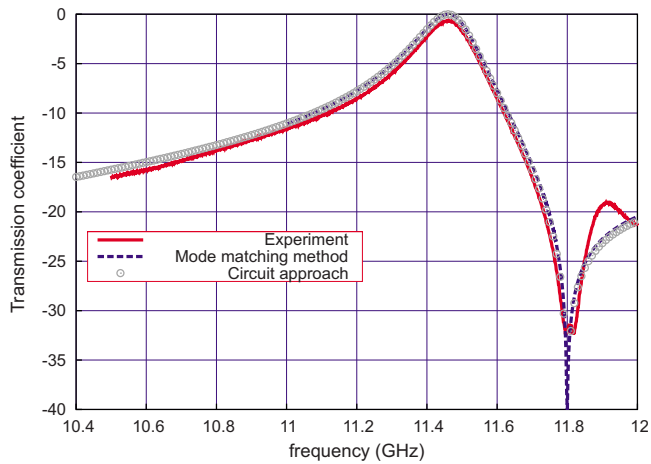

FIG. 2. (Color online) Transmission coefficient (dB) for the structure in Fig. 1. Note the presence of total transmission with low losses (0.7 dB) at 11.42 GHz and almost total reflection (transmission level is about -32 dB) at 11.80 GHz.

sion according to our theory.¹⁵ Low reflection coaxial to rectangular waveguide as well as rectangular waveguide to circular waveguide transitions have been used to obtain very low reflection levels within the frequency band of interest in the absence of the diaphragm (a reflectivity better than -30 dB was measured). Using this setup, we have measured the transmission coefficient when the diaphragm was placed in the middle of the circular waveguide section. The corresponding experimental data are plotted in Fig. 2. The same coefficient was computed using a mode matching method²³ whose convergence was exhaustively tested. A very good agreement can be appreciated in the above figure between the numerical and experimental data (note that metal losses were not included in the numerical simulations thus explaining slight differences in the transmission level). Moreover, the circuit model in Fig. 1(b) was also used to reproduce the same results after extracting the values of C_0 , $A_{TM_{01}}$, and L from a few low-frequency numerically generated full-wave data. Again, the agreement shown in Fig. 2 is very good. Above the cutoff frequency of the TM_{01} mode, the agreement is not good but it is expected because this mode is launched by the different transitions of the experimental setup, thus modifying the reflectivity of such transitions (which were designed to operate with a single propagating mode; namely, the TE_{11} mode).

The relevant point of the observed data is that the size of the slit diaphragm corresponds to a resonance frequency of approximately 15 GHz. However, a total transmission peak is observed at 11.42 GHz, a frequency slightly below the transmission zero corresponding to the cutoff frequency of the TM_{01} mode (11.80 GHz in our case; this is what in 1D and 2D diffraction gratings is known as the first Rayleigh-

Wood anomaly). We believe that the above experiment clearly validates the impedance matching point of view to explain the ET phenomenon. Thus, the impedance matching model accounts for 2D periodic arrays of holes (as it was demonstrated in Ref. 15) as well as for the nonperiodic enhanced-transmission system discussed in this contribution. Our theory also matches the general point of view on this and other related topics reported in a recent review paper,²⁴ where the interaction of open resonators with plane waves is considered to be the essence of the phenomenon.

The authors would like to acknowledge the support of this research by the Spanish Ministry of Science and Innovation and European Union Feder Funds (Grant Nos. TEC2007-65376 and Consolider Ingenio 2010 CSD2008-00066) and by the Spanish Junta de Andalucía (Project No. TIC-253).

- ¹T. W. Ebbesen, H. J. Lezec, H. F. Ghaemi, T. Thio, and P. A. Wolff, *Nature (London)* **391**, 667 (1998).
- ²C. Genet and T. W. Ebbesen, *Nature (London)* **445**, 39 (2007).
- ³M. Beruete, M. Sorolla, I. Campillo, L. Martín-Moreno, J. Bravo-Abad, and F. J. García-Vidal, *IEEE Trans. Antennas Propag.* **53**, 1897 (2005).
- ⁴F. J. García-de-Abajo, *Rev. Mod. Phys.* **79**, 1267 (2007).
- ⁵J. B. Pendry, L. Martín-Moreno, and F. J. García-Vidal, *Science* **305**, 847 (2004).
- ⁶M. J. Kofke, D. H. Waldeck, Z. Fakhraai, S. Ip, and G. C. Walker, *Appl. Phys. Lett.* **94**, 023104 (2009).
- ⁷C. R. Williams, S. R. Andrews, S. A. Maier, A. I. Fernández-Domínguez, L. Martín-Moreno, and F. J. García-Vidal, *Nat. Photonics* **2**, 175 (2008).
- ⁸C. C. Cutler, Bell Telephone Laboratories Report No. MM-44-160-218, 1944.
- ⁹W. Rotman, *Proc. IRE* **39**, 952 (1951).
- ¹⁰L. O. Goldstone and A. A. Oliner, *IEEE Trans. Antennas Propag.* **7**, 274 (1959).
- ¹¹R. E. Collin, *Field Theory of Guided Waves* (IEEE, New York, 1971).
- ¹²W. L. Barnes, A. Dereux, and T. W. Ebbesen, *Nature (London)* **424**, 824 (2003).
- ¹³A. V. Zayats and I. I. Smolyaninov, *J. Opt. A, Pure Appl. Opt.* **5**, S16 (2003).
- ¹⁴T. Matsui, A. Agrawal, A. Nahata, and Z. V. Vardeny, *Nature (London)* **446**, 517 (2007).
- ¹⁵F. Medina, F. Mesa, and R. Marqués, *IEEE Trans. Microwave Theory Tech.* **56**, 3108 (2008).
- ¹⁶R. Marqués, F. Mesa, L. Jelinek, and F. Medina, *Opt. Express* **17**, 5571 (2009).
- ¹⁷R. Gordon, *Phys. Rev. A* **76**, 053806 (2007).
- ¹⁸Y. Pang, A. N. Hone, P. P. M. So, and R. Gordon, *Opt. Express* **17**, 4433 (2009).
- ¹⁹A. A. Kirilenko and A. O. Perov, *IEEE Trans. Antennas Propag.* **56**, 3210 (2008).
- ²⁰N. G. Don, A. A. Kirilenko, and S. L. Senkevich, *Radiophys. Quantum Electron.* **51**, 101 (2008).
- ²¹Z. Ruan and M. Qiu, *Phys. Rev. Lett.* **96**, 233901 (2006).
- ²²B. A. Munk, *Frequency Selective Surfaces: Theory and Design* (Wiley, New York, 2000).
- ²³R. H. MacPhie and K. L. Wu, *IEEE Trans. Microwave Theory Tech.* **43**, 2041 (1995).
- ²⁴K. Y. Bliokh, Y. P. Bliokh, V. Freilikher, S. Savelév, and F. Nori, *Rev. Mod. Phys.* **80**, 1201 (2008).